



Steel laminae couplings

Types and operating description 186

RADEX®-N

General information and hub types 188

Types and applications 189

Technical data 190

Standard types 192

Customised types 194

Corrosion-resistant type for large shaft distances 195

Standard series NANA 3 for Pump drives in accordance with API 610 196



RIGIFLEX®-N

General information and hub types 198

Technical data 199

Type A 201

Type A-J 202

Type A-H 203

RIGIFLEX®-HP

Type C 204

Type L 205

Please note: torque increase



Years of experience with applications at customer sites and additional test series in the KTR test field in Rheine enabled us to determine potentials allowing for an increase of rated and maximum torques with some sizes of this series:

RADEX®-N



RIGIFLEX®-N



RIGIFLEX®-HP



STEEL LAMINAE COUPLINGS

TYPES AND OPERATING DESCRIPTION

Properties of laminae couplings



Product	RADEX®-N	RIGIFLEX®-N	RIGIFLEX®-HP
Type	Steel laminae coupling		High-performance steel laminae coupling
Properties			
Torsionally rigid	●	●	●
Backlash-free	●	●	●
Maintenance-free	●	●	●
Compensating for misalignment	●	●	●
Special features			
Stock programme	Basic programme available from stock, customised solutions available	Basic programme available from stock, customised solutions available	For customised solutions, applications in high performance ranges and on high-speed drives
Applications / core industries	Pumps, compressors, fans	Pumps, compressors, fans	Pumps, turbo compressors, turbines
API	610	610 & 671	610 & 671
Performance data			
Max. rated torque T_{KN} [Nm]	280,000	280,000	330,000
Max. speed n [rpm]	20,000	23,000	17,300
Max. operating temperature T [°C]	280	280	280
Standard materials			
Hubs			
Steel (S355J2)	●	●	
Q & T steel (C45N)	●	●	
Q & T steel (42CrMo4V)			●
Q & T steel (30CrNiMo8)			●
Spacers			
Steel (S355J2)	●	●	
Q & T steel (C45N)	●	●	
Q & T steel (42CrMo4V)	with torsion shafts		●
Q & T steel (30CrNiMo8)	with torsion shafts		●
Special materials (corrosion-resistant)			
Hubs			
Steel (1.4305)	●	○	○
Steel (1.4404)	●		
Spacers			
Steel (1.4305)	●		
Steel (1.4404)	●		
Spacer made of Composite GRP (fibre glass)	●	○	○
Spacer made of Composite CFRP (carbon fibre)	●		
Surface coating	Painting, phosphating, zinc-coating and passivating, Geomet, Tenifer Q	Painting, phosphating, zinc-coating and passivating, Geomet, Tenifer Q	Painting, phosphating, zinc-coating and passivating, Geomet, Tenifer Q

● ≈ Standard
○ ≈ On request

STEEL LAMINAE COUPLINGS

TYPES AND OPERATING DESCRIPTION

Product finder of laminae couplings

			
Product	RADEX®-N	RIGIFLEX®-N	RIGIFLEX®-HP
Type	Steel laminae coupling		High-performance steel laminae coupling
Geometries			
Design	Single- and double-cardanic	Double-cardanic	Double-cardanic
Max. shaft diameter [mm]	330	400	380
Radial assembly	●	●	●
Certifications/type examinations			
ATEX 	●	●	-
GOST R/ GOST TR 	●	●	●
DNV GL 	●	●	●
ABS 	●	●	-

● ≈ Standard

Details on laminae couplings

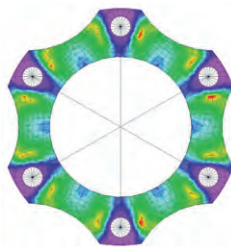
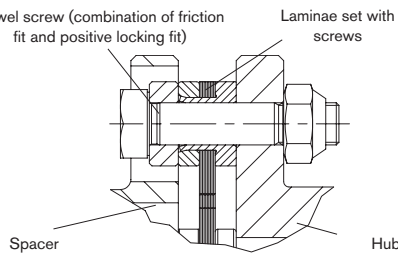
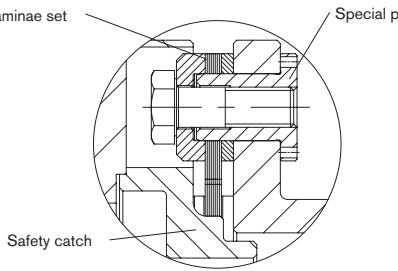
<p>Laminas - laminae shape optimized by FEM</p> <p>The steel laminae sets made of high-strength, stainless spring steel were developed based on FEM calculations. Considering the necessary options of displacement of the coupling, the optimum shape with regard to torque transmission and torsional stiffness was aimed at. The waisted shape of the steel laminas on the outside diameter resulted from this optimization calculation.</p>	
<p>RADEX®-N - laminae sets with dowel screws</p> <p>The heart of the steel laminae coupling are the laminae sets and their connection to hubs and spacers. High-strength special dowel screws that are alternately screwed to hubs and spacer allow for a combination of friction fit and positive locking fit. Thus a high power density with simultaneous ease of displacement and low restoring forces is ensured.</p>	
<p>RIGIFLEX®-N - protecting the spacer</p> <p>Since our main idea with the development of RIGIFLEX®-N was to comply with the standards of API 610 and API 671, the spacer is secured by a safety catch, too. In case if the laminas break the spacer remains inside the coupling. In general the spacer is supplied along with laminae sets pre-assembled by the manufacturer. These are connected with the spacers resp. flanges fully free from backlash via positive-locking special pins.</p>	

RADEX®-N

Steel laminae couplings

General advice

Advice on assembly and operation

See our mounting instructions KTR standard 47110 at www.ktr.com. With the assembly it is important to make sure that the laminae sets are assembled free from distortion in axial direction. If the finish bore is machined by the customer, the concentricity and axial running tolerances have to be adhered to (see sketch).

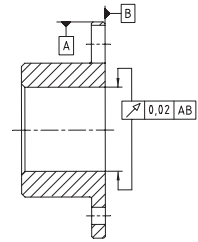

Installation

RADEX®-N couplings are designed for horizontal installation. With vertical installation the spacer might have to be supported (see sketch). Please consult with us.

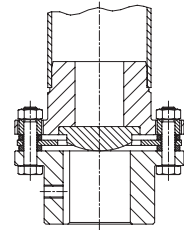

Delivery condition

RADEX®-N couplings are delivered as individual components (can be delivered assembled on request). The hubs can be supplied unbored or with finish bore and feather keyway or with a frictionally engaged shaft-hub-connection. The shaft-hub-connection needs to be inspected by the customer (consult with KTR, if necessary).



Balancing

On request of the customer the RADEX®-N couplings can be balanced. For standard applications this is not necessary due to accurate machining of the coupling. Please consult with us, if necessary.

Safety regulations

The coupling has to be dimensioned in that the permissible coupling load is not exceeded during any operating condition. For this purpose the actual loads have to be compared to the permissible parameters of the coupling. The customer has to protect rotating parts from accidental contact (Safety of Machinery DIN EN 292 part 2). Take precautions to make sure there is sufficient coupling protection in case of fracture of the coupling caused by overload.

Types of hubs

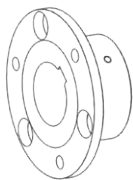

Type 1.0 hub with feather keyway and setscrew

Positive locking torque transmission, permissible torque depending on the permissible surface pressure. Not suitable for backlash-free torque transmission with heavily reversing operation.

Type 1.1 hub without feather keyway, with setscrew

Non-positive torque transmission for crimp connections and adhesive bonds. (No ATEX approval)

Type 1.2 hub without feather keyway, without setscrew

Non-positive torque transmission for crimp connections and adhesive bonds. (No ATEX approval)

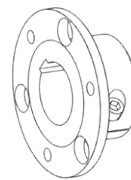

Type 2.5 clamping hub double slotted, without feather keyway

Frictionally engaged, backlash-free shaft-hub-connection. Transmittable torques depending on bore diameter. For ATEX category 3 only.

Type 2.6 clamping hub double slotted, with feather keyway

Positive shaft-hub connection with additional friction fit. The friction fit prevents respectively reduces reverse backlash.

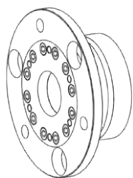

Type 6.0 clamping ring hub

Integrated frictionally engaged shaft-hub-connection for the transmission of higher torques. Clamping screws on laminae side. Transmittable torques depending on bore diameter. Suitable for high speeds.

Type 6.5 clamping ring hub

Integrated frictionally engaged shaft-hub-connection for the transmission of higher torques. Clamping screws from outside. Transmittable torques depending on bore diameter. Suitable for high speeds.

RADEX®-N

Steel laminae couplings

Types and applications

Type NN (see page 192)

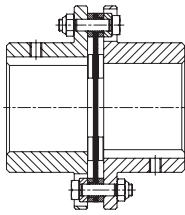

Type NANA 1/NANA 2 (see page 192)

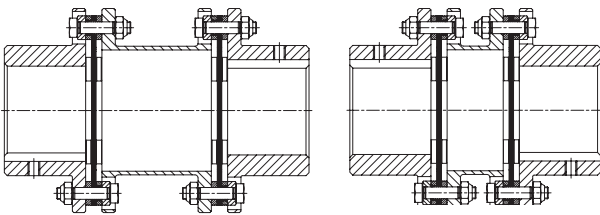

Type NANA 3 (see page 196)

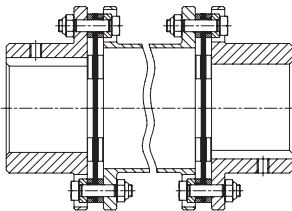

Type NANA 4 (see page 194)

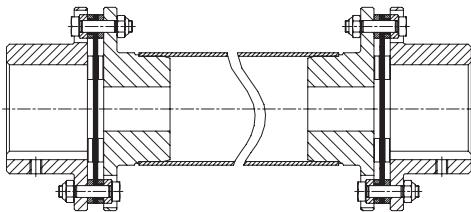

Type NNW (see page 194)

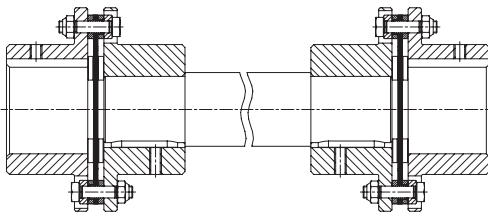

Type NNZ (see page 193)

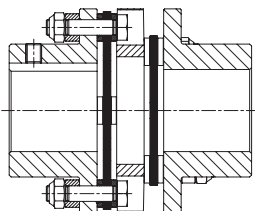

Type NENE (see page 193)

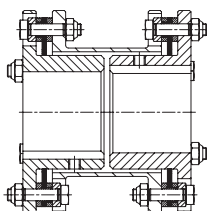

Properties

- Single-cardanic type
- Only angular and axial displacement permissible
- High torsional rigidity
- Compact dimensions

Applications

- Mixers
- Agitators
- Immersion pumps
- Fans
- Applications with high radial load

- Double-cardanic type
- Compensating for high misalignment with low restoring forces
- Standard spacers available from stock

- Paper machines
- Printing and processing machines
- Materials handling
- Steel mills
- Generators
- Mill drives

- Double-cardanic type
- Spacers adapted to standard dimensions of pumps
- Radial assembly, no shifting of the machine required
- Available according to API 610

- Process pumps
- Water pumps
- Pumps according to API standard
- Turbines
- Compressors

- Customised spacers
- Max. shaft distance dimension up to approx. 6 m
- Welded intermediate pipes for high torsional rigidity

- Foil and paper machines
- Pallet and conveyor systems
- Robotic palletizers
- Test benches
- Cooling towers/blowers

- Customised spacers
- Coupling consisting of 2-off type NN with intermediate shaft
- For drives with relatively low speeds

- Low-speed drives with large shaft distance dimensions
- Agitators
- Crushers
- Presses
- Packaging machinery

- Compact double-cardanic coupling
- Cannot be radially assembled
- With intermediate disk
- Ideal for replacing curved-tooth gear couplings made of steel
- Standard type up to size 70

- Robotics
- Paper machines and inserters
- Machine tools
- Packaging machinery
- Test benches

- With reduced hubs
- Compact double-cardanic design
- Spacer cannot be radially assembled
- Variable spacer length

- Applications with short shaft distance dimensions
- Replacement of curved-tooth gear couplings made of steel

RADEX®-N

Steel laminae couplings

Technical data

The following laminae types are to be distinguished with RADEX®-N:

Size 20 – 50
(laminae with 4 holes)

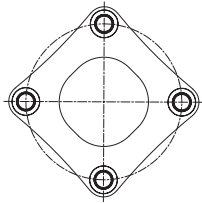

Size 60 – 135
(laminae with 6 holes)

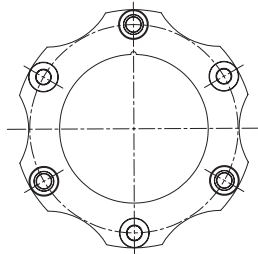

Size 136 – 336
(laminae with 6 holes)

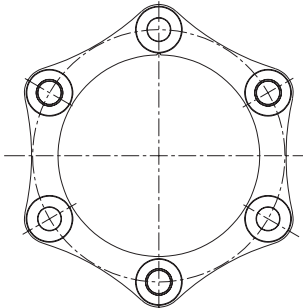

Size 138 – 338
(laminae with 8 holes)

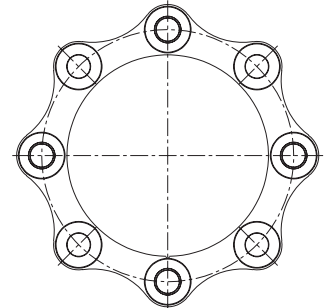

Torques and displacements									
Size	Laminae type	Torques [Nm] ¹⁾				Perm. displacements ²⁾			
		T _{KN}	T _{K max}	T _{KW}	Angular [°] each laminae	Axial [mm]		Radial [mm]	
						NN	NANA 1/ NANA2/ NNZ	NANA 1	NANA 2
20		30	60	15	1.0	0.60	1.2	1.0	0.2
25		60	120	30	1.0	0.80	1.6	1.0	0.2
35	laminae with 4 holes	120	240	60	1.0	1.00	2.0	1.1	0.3
38		240	480	120	1.0	1.20	2.4	1.2	0.3
42		320	640	160	1.0	1.40	2.8	1.2	0.4
50		470	940	235	1.0	1.60	3.2	1.5	0.4
60		900	1800	450	1.0	1.00	2.0	1.5	0.8
70		1300	2600	650	1.0	1.10	2.2	1.8	1.0
80		1800	3600	900	1.0	1.30	2.6	2.1	1.2
85		2600	5200	1300	1.0	1.30	2.6	2.2	1.2
90		4600	9200	2300	1.0	1.00	2.0	2.2	1.1
105		5600	11200	2800	1.0	1.20	2.4	2.4	1.4
115		9900	19800	4950	1.0	1.40	2.8	2.5	1.5
135	laminae with 6 holes	13500	27000	6750	1.0	1.75	3.5	3.8	–
136		17500	35000	8750	0.7	1.85	3.7		
156		25000	50000	12500	0.7	2.10	4.2		
166		35000	70000	17500	0.7	2.25	4.5		
186		42000	84000	21000	0.7	2.40	4.8		
206		52500	105000	26250	0.7	2.60	5.2		
246		90000	180000	45000	0.7	3.00	6.0		
286		150000	300000	75000	0.7	3.35	6.7		
336		210000	420000	105000	0.7	3.75	7.5		
138		23000	46000	11500	0.5	1.30	2.6	Depending on drop-out center dimension E	
158	33000	66000	16500	0.5	1.40	2.8			
168	45000	90000	22500	0.5	1.50	3.0			
188	56000	112000	28000	0.5	1.60	3.2			
208	70000	140000	35000	0.5	1.75	3.5			
248	120000	240000	60000	0.5	2.00	4.0			
288	200000	400000	100000	0.5	2.40	4.5			
338	280000	560000	140000	0.5	2.50	5.0			

¹⁾ = Years of experience with applications at customer sites and additional test series in the KTR test field in Rheine enabled us to determine potentials allowing for an increase of the rated and maximum torques with some sizes of this series.

Permissible speeds and torsional stiffness figures					
Size	Max. speed [rpm] (higher speeds on request)	Torsion spring stiffness x 10 ⁶ [Nm/ rad] per laminae set	Size	Max. speed [rpm] (higher speeds on request)	Torsion spring stiffness x 10 ⁶ [Nm/ rad] per laminae set
20	20400	0.02	156	3500	17.00
25	16800	0.03	166	3300	19.00
35	13900	0.11	186	3000	25.00
38	12000	0.20	206	2800	31.00
42	11000	0.28	246	2300	55.00
50	9000	0.50	286	2000	79.00
60	8200	0.56	336	1800	125.00
70	7300	0.90	138	3800	20.00
80	6300	1.10	158	3500	26.00
85	5900	1.50	168	3300	30.00
90	5400	2.00	188	3000	39.00
105	5000	2.50	208	2800	49.00
115	4300	3.50	248	2300	83.00
135	3700	6.90	288	2000	125.00
136	3800	13.00	338	1800	200.00

¹⁾ For selection of coupling see page 18 et seqq.

²⁾ The permissible displacement figures specified are maximum figures which must not arise simultaneously. If axial, radial and angular displacement arises at the same time, these values must be reduced.

RADEX[®]-N

Steel laminae couplings

Technical data

Weights and mass moments of inertia						
Size	Hub ¹⁾ [kg] / [kgm ²]	Laminae set [kg] / [kgm ²]	NN ¹⁾ complete [kg] / [kgm ²]	NANA 1 ¹⁾ complete [kg] / [kgm ²]	NANA 2 ¹⁾ complete [kg] / [kgm ²]	NNZ ¹⁾ complete [kg] / [kgm ²]
20	0.13 / 0.000043	0.04 / 0.00002	0.3 / 0.00011	0.6 / 0.000204	–	0.4 / 0.000166
25	0.2 / 0.000116	0.08 / 0.00005	0.56 / 0.00028	0.9 / 0.000522	–	0.8 / 0.000414
35	0.6 / 0.00042	0.10 / 0.00010	1.2 / 0.00094	1.9 / 0.00158	–	1.6 / 0.00129
38	0.8 / 0.00073	0.20 / 0.00026	1.8 / 0.0017	2.8 / 0.00303	–	2.4 / 0.00247
42	1.1 / 0.00123	0.25 / 0.00040	2.4 / 0.0029	3.6 / 0.00482	–	3.1 / 0.00409
50	1.7 / 0.00291	0.46 / 0.0010	4.0 / 0.0068	6.2 / 0.0118	–	5.1 / 0.00932
60	1.9 / 0.00378	0.40 / 0.0012	4.2 / 0.0087	6.0 / 0.0141	5.8 / 0.0138	5.3 / 0.0120
70	2.8 / 0.00714	0.42 / 0.0016	6.0 / 0.016	8.6 / 0.0253	8.2 / 0.0242	7.5 / 0.0214
80	4.1 / 0.0134	0.72 / 0.0037	9.0 / 0.031	12.6 / 0.0476	12.0 / 0.0458	11.1 / 0.0410
85	5.1 / 0.0195	1.0 / 0.0065	11.2 / 0.046	16.2 / 0.0734	15.5 / 0.0711	14.8 / 0.0650
90	6.2 / 0.0282	2.3 / 0.0162	14.7 / 0.073	22.0 / 0.121	21.3 / 0.119	20.1 / 0.108
105	7.6 / 0.0414	2.2 / 0.0180	17.4 / 0.101	25.8 / 0.165	24.6 / 0.159	23.1 / 0.145
115	12.0 / 0.0899	4.0 / 0.0433	27.9 / 0.223	42.8 / 0.381	41.2 / 0.372	38.3 / 0.333
135	19.0 / 0.187	7.3 / 0.105	45.1 / 0.478	71.3 / 0.835	–	–
136	16.8 / 0.153	7.9 / 0.113	41.4 / 0.419	–	–	–
156	20.2 / 0.217	11.9 / 0.200	52.2 / 0.634	–	–	–
166	30.0 / 0.373	12.3 / 0.255	72.3 / 1.001	–	–	–
186	42.0 / 0.629	12.7 / 0.318	96.7 / 1.576	–	–	–
206	55.1 / 1.004	18.2 / 0.548	128.3 / 2.556	–	–	–
246	85.9 / 2.229	31.2 / 1.304	203.1 / 5.762	–	–	–
286	145.1 / 4.977	44.4 / 2.495	334.4 / 12.449	–	–	–
336	223.9 / 10.486	64.2 / 4.74	512.0 / 25.712	–	–	–
138	16.2 / 0.145	9.9 / 0.143	42.3 / 0.433	Depending on drop-out center dimension	Depending on drop-out center dimension E	–
158	19.5 / 0.205	14.9 / 0.252	54.0 / 0.662	–	–	–
168	29.4 / 0.360	15.2 / 0.318	74.0 / 1.038	–	–	–
188	41.7 / 0.611	15.6 / 0.396	99.0 / 1.618	–	–	–
208	54.1 / 0.971	22.4 / 0.680	130.5 / 2.622	–	–	–
248	84.0 / 2.144	38.2 / 1.605	206.2 / 5.893	–	–	–
288	142.5 / 4.823	53.8 / 3.056	338.8 / 12.702	–	–	–
338	220.1 / 10.18	78.0 / 5.817	518.2 / 26.177	–	–	–

¹⁾ Hubs with max. bore

Cylindrical bores

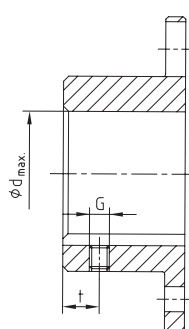

Standard hub 1.0 with feather keyway according to DIN 6885 sheet 1									
Size	d _{max.}	G	t	T _A [Nm]	Size	d _{max.}	G	t	T _A [Nm]
20	20	M5	6	2.0	105	110	M12	30	40.0
25	25	M5	8	2.0	115	120	M12	30	40.0
35	38	M6	15	4.8	135	135			
38	42	M6	15	4.8	136 / 138	135			
42	50	M8	20	10.0	156 / 158	150			
50	55	M8	20	10.0	166 / 168	170			
60	65	M8	20	10.0	186 / 188	190			
70	75	M10	20	17.0	206 / 208	210			
80	85	M10	20	17.0	246 / 248	245			
85	90	M10	25	17.0	286 / 288	290			
90	100	M12	25	40.0	336 / 338	340			

Backlash-free shaft-hub connections without feather key

Selection: If used in potentially explosive atmospheres the clamping ring hubs must be selected in that there is a minimum safety factor of $s = 2$ between the peak torque of the machine including all operating parameters and the nominal torque and frictional locking torque of the coupling.

Clamping ring hub type 6.5
(clamping screws from outside)

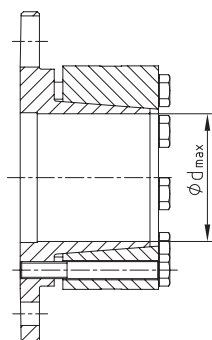

Clamping ring hub type 6.0
(clamping screws from inside)

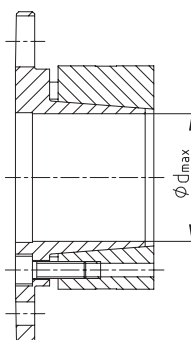

Type with CLAMPEX[®] element type 603

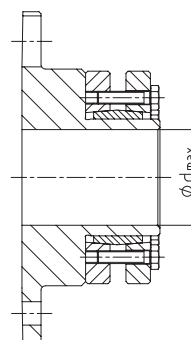

RADEX®-N NN, NANA 1 and NANA 2 Steel laminae couplings

Standard types

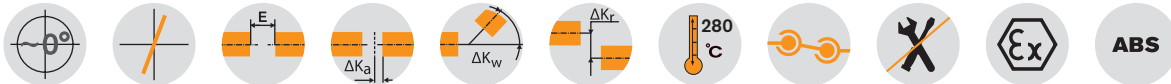
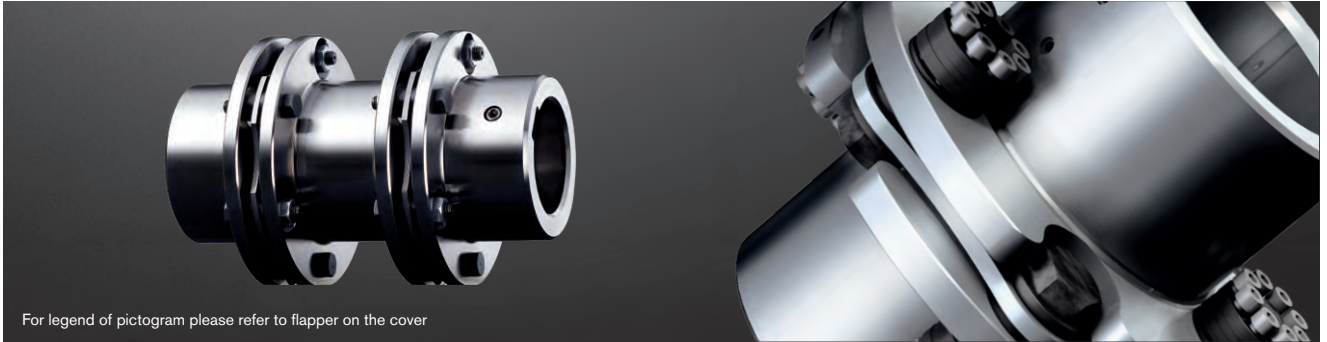

Components

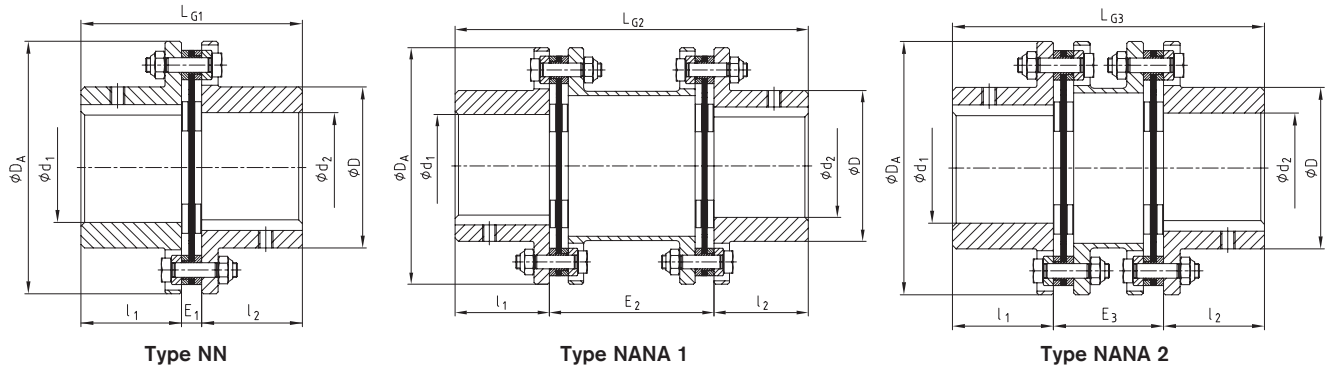

RADEX®-N Types NN, NANA 1, NANA 2										
Size	Max. finish bore		Dimensions [mm]							
	d ₁ , d ₂	D	D _A	l ₁ , l ₂	L _{G1}	E ₁	L _{G2}	E ₂	L _{G3}	E ₃
20	20	32	56	20	45	5	100	60	-	-
25	25	40	68	25	56	6	110	60	-	-
35	38	54	82	40	86	6	150	70	-	-
38	42	58	94	45	98	8	170	80	-	-
42	50	68	104	45	100	10	170	80	-	-
50	55	78	126	55	121	11	206	96	-	-
60	65	88	138	55	121	11	206	96	170	60
70	75	102	156	65	141	11	246	116	200	70
80	85	117	179	75	164	14	286	136	233	83
85	90	123	191	80	175	15	300	140	246	86
90	100	132	210	80	175	15	300	140	251	91
105	110	147	225	90	200	20	340	160	281	101
115	120	163	265	100	223	23	370	170	309	109
135	135	184	305	135	297	27	520	250	-	-
136	135	180	300	135	293	23				
156	150	195	325	150	327	27				
166	170	225	350	165	361	31				
186	190	250	380	185	401	31				
206	210	275	420	200	437	37				
246	245	320	500	240	524	44				
286	290	383	567	280	612	52				
336	340	445	660	330	718	58				
138	135	180	300	135	293	23				
158	150	195	325	150	327	27				
168	170	225	350	165	361	31				
188	190	250	380	185	401	31				
208	210	275	420	200	437	37				
248	245	320	500	240	524	44				
288	290	383	567	280	612	52				
338	340	445	660	330	718	58				

Ordering example:	RADEX®-N 60	NANA 1	Ø50	Ø60
	Coupling size	Type	Finish bore d ₁	Finish bore d ₂

RADEX®-N NENA 1, NENA 2, NENE and NNZ Steel laminae couplings

Standard types



For legend of pictogram please refer to flapper on the cover

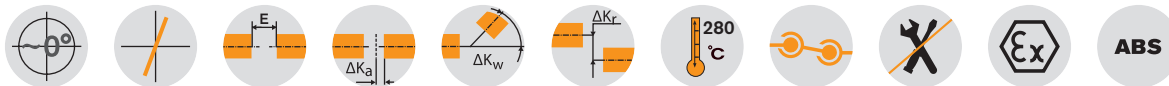

Components

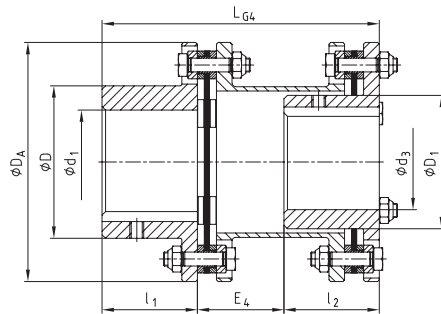

Type NENA 1

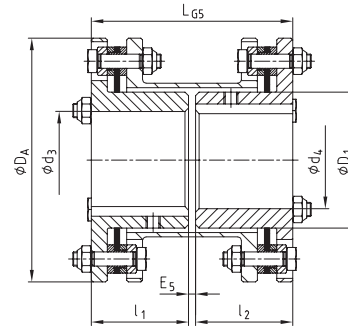

Type NENE

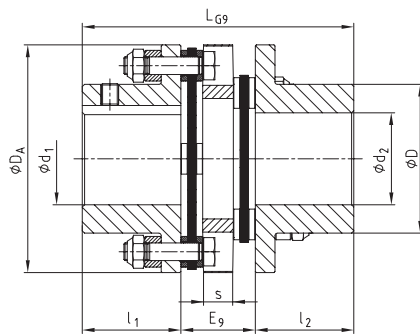

Type NNZ

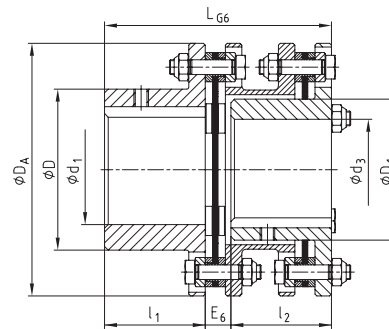

Type NENA 2

RADEX®-N Types NENA 1, NENE, NENA 2, NNZ

Size	Max. finish bore		Dimensions [mm]												
	d ₁ , d ₂	d ₃ , d ₄	D	D ₁	D _A	l ₁ , l ₂	L _{G4}	E ₄	L _{G5}	E ₅	L _{G6}	E ₆	L _{G9}	E ₉	
20	20	-	32	-	56	20	-	-	-	-	-	-	58	18	
25	25	-	40	-	68	25	-	-	-	-	-	-	70	20	
35	38	-	54	-	82	40	-	-	-	-	-	-	102	22	
38	42	-	58	-	94	45	-	-	-	-	-	-	118	28	
42	50	-	68	-	104	45	-	-	-	-	-	-	124	34	
50	55	-	78	-	126	55	-	-	-	-	-	-	144	34	
60	65	55	88	77	138	55	160	50	114	4	124	14	144	34	
70	75	65	102	90	156	65	190	60	134	4	144	14	166	36	
80	85	75	117	104	179	75	220	70	154	4	167	17	-	-	
85	90	80	123	112	191	80	232	72	164	4	178	18	-	-	
90	100	85	132	119	210	80	233	73	166	6	184	24	-	-	
105	110	90	147	128	225	90	263	83	186	6	204	24	-	-	
115	120	100	163	145	265	100	288	88	206	6	227	27	-	-	

Ordering example:

RADEX®-N 60	NENA 1	Ø50	Ø60
Coupling size	Type	Finish bore d ₁	Finish bore d ₂

RADEX®-N NANA 4 and NNW Steel laminae couplings

Customised types

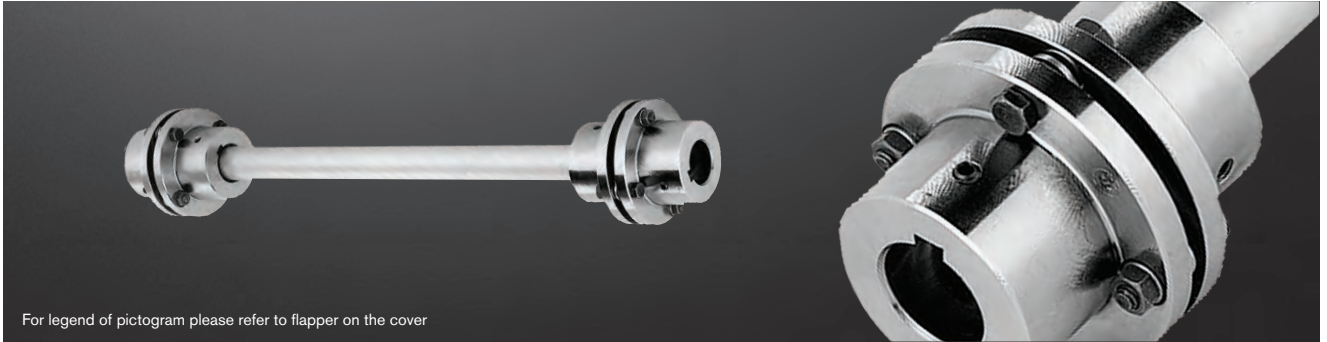

For legend of pictogram please refer to flapper on the cover



Components

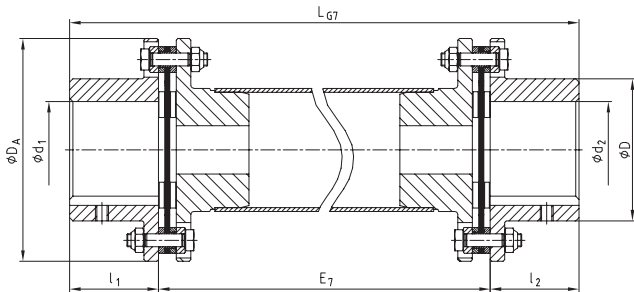

Type NANA 4

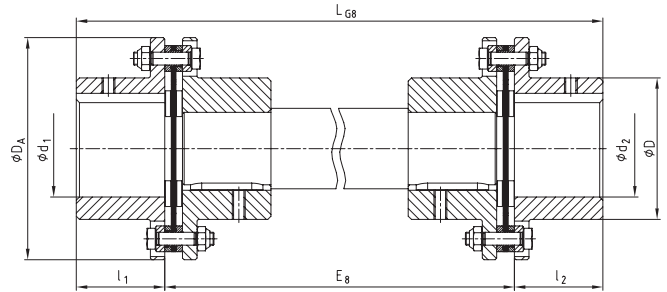

Type NNW

RADEX®-N Types NANA 4, NNZ and NNW								
Size	Max. finish bore	Dimensions [mm]						
	d ₁ , d ₂	D	DA	l ₁ , l ₂	LG7	E7	LG8	E8
20	20	32	56	20				
25	25	40	68	25				
35	38	54	82	40				
38	42	58	94	45				
42	50	68	104	45				
50	55	78	126	55				
60	65	88	138	55				
70	75	102	156	65				
80	85	117	179	75				
85	90	123	191	80				
90	100	132	210	80				
105	110	147	225	90				
115	120	163	265	100				
135	135	184	305	135				
136	135	180	300	135				
156	150	195	325	150				
166	170	225	350	165				
186	190	250	380	185				
206	210	275	420	200				
246	245	320	500	240				
286	290	383	567	280				
336	340	445	660	300				
138	135	180	300	135				
158	150	195	325	150				
168	170	225	350	165				
188	190	250	380	185				
208	210	275	420	200				
248	245	320	500	240				
288	290	383	567	280				
338	340	445	660	300				
					LG7 = E7 + l ₁ + l ₂	Intermediate shaft dimension according to customer specification	LG8 = E8 + l ₁ + l ₂	Intermediate shaft dimension according to customer specification

Ordering example:	RADEX®-N 60	NANA 4	Ø50	Ø60	2500
	Coupling size	Type	Finish bore d ₁	Finish bore d ₂	Shaft distance dimension

RADEX®-N Composite Steel laminae couplings

Corrosion-resistant type for large shaft distances



For legend of pictogram please refer to flapper on the cover



Components

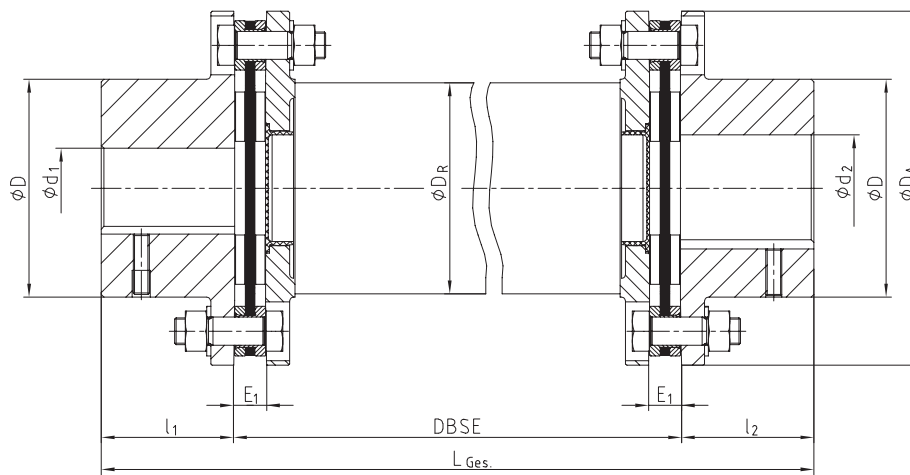

RADEX®-N Type NANA 4 CFK

Size	Torque [Nm] ¹⁾		Dimensions [mm]								
	T _{KN}	T _{K max}	D _A	d ₁ , d ₂ max.	D	l ₁ , l ₂	E ₁	DBSE	L _{total}	Composite tube D _R	Max. DBSE ²⁾ with 1500 rpm
70	800	1600	149	75	102	65	11	As specified by the customer	l ₁ + l ₂ + DBSE	95	3500
85	1800	3600	184	90	123	80	15			117	3900
90	2500	5000	200	100	135	80	15			128	4100
115	4500	9000	253	120	163	100	23			160	4600

¹⁾ For selection of coupling see page 18 et seqq.

²⁾ For higher speeds or bigger shaft distance dimensions please consult with KTR (+49 5971 798-484). The above-mentioned characteristic figures (e. g. max. DBSE) can be varied by composite tubes optimized for the application, if necessary.

Particularly the steel laminae couplings are well suited for applications with especially large distance dimensions between the drive and the driven side (e. g. cooling towers, fans etc.) due to their design. In order to generate high speeds with large distance dimensions, RADEX®-N couplings with intermediate shafts made of glass fibre or carbon fibre reinforced nylon (GRP or CFRP) are used, if necessary.

Ordering
example:

RADEX®-N 85	NANA 4 CFK	Ø60	Ø70	3000
Coupling size	Type	Finish bore d ₁	Finish bore d ₂	Shaft distance dimension

RADEX®-N NANA 3

Steel laminae couplings

Pump drives in accordance with API 610



For legend of pictogram please refer to flapper on the cover



RADEX®-N type NANA 3							
Size	Max. finish bore	Dimensions [mm]				Perm. displacements	
	d	D	D _A	E _{standard} ¹⁾	l ₁ , l ₂	Angular [°] each laminae	Axial [mm]
42	50	68	104	100	45	1.0	2.8
50	55	78	126	140/180	55	1.0	3.2
60	65	88	138	100/140/180/250	55	1.0	2.0
70	75	102	156	100/140/180	65	1.0	2.2
80	85	117	179	100/140/180/250	75	1.0	2.6
85	90	123	191	100/140/180/250	80	1.0	2.3
90	100	132	210	140/180/250	80	1.0	2.0
105	110	147	225	250	90	1.0	2.4
115	120	163	265	250	100	1.0	2.8
135	135	184	305	250	135	1.0	3.5
136	135	180	300		135	0.7	3.7
156	150	195	325		150	0.7	4.2
166	170	225	350		165	0.7	4.5
186	190	250	380		185	0.7	4.8
206	210	275	420		200	0.7	5.2
246	245	320	500		240	0.7	6.0
286	290	383	567		280	0.7	6.7
336	340	445	660		330	0.7	7.5
138	135	180	300		135	0.5	2.6
158	150	195	325		150	0.5	2.8
168	170	225	350	As specified by the customer	165	0.5	3.0
188	190	250	380		185	0.5	3.2
208	210	275	420		200	0.5	3.5
248	245	320	500		240	0.5	4.0
288	290	383	567		280	0.5	4.5
338	340	445	660		330	0.5	5.0

¹⁾ Other distance dimensions E available on request.

Ordering example:	RADEX®-N 60	NANA 3	Ø50	Ø60	140
		Coupling size	Type	Finish bore d ₁	Finish bore d ₂

Components

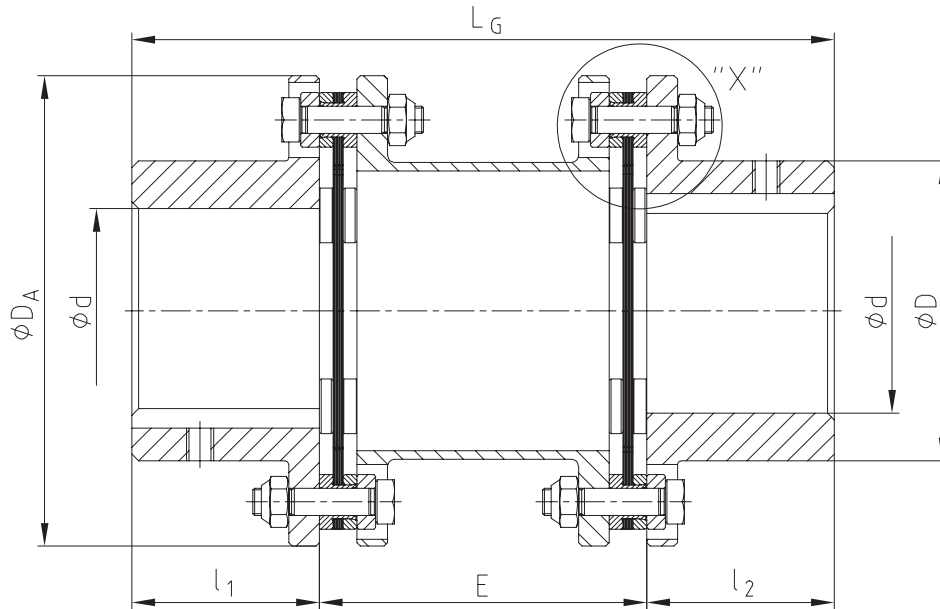

Detail "X"

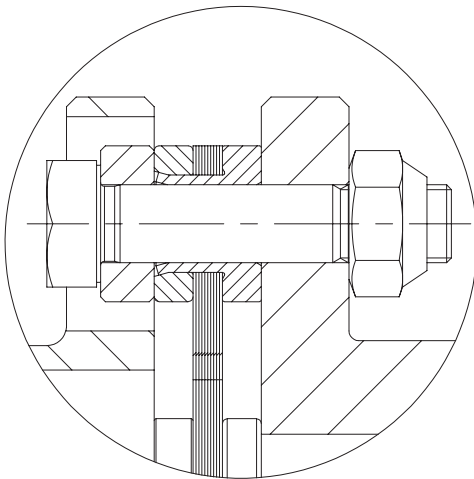

Safety catch of the spacer:
The laminae sets are provided with a sleeve in order to fasten the spacer if the laminas break.

RIGIFLEX®-N

Steel laminae couplings

General advice

Advice on assembly and operation

See our mounting instructions KTR standard 47410 at www.ktr.com. With the assembly it is important to make sure that the laminae sets are assembled free from distortion in axial direction.

If the finish bore is machined by the customer, the tolerances for concentricity and axial run-out have to be observed (see illustrations below).

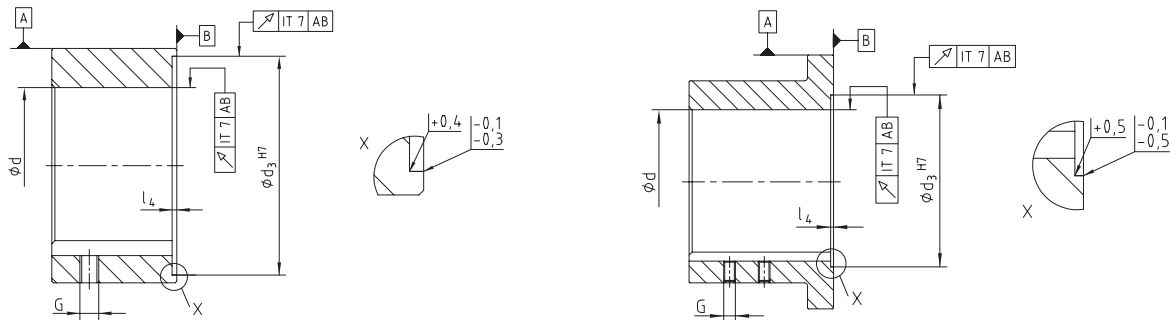

Installation

RIGIFLEX®-N couplings are designed for horizontal installation. With vertical installation the spacer has to be supported, if necessary. Please consult with us.

Delivery condition

RIGIFLEX®-N-couplings are supplied as individual components (assembled on request), with the subassembly of spacers (flanges, laminae sets and spacer) being fully assembled. The hubs can be supplied unbored or with finish bore and feather keyway or with a frictionally engaged shaft-hub-connection. The shaft-hub-connection needs to be inspected by the customer (consult with KTR, if necessary).

Balancing

On request of the customer the RIGIFLEX®-N couplings can be balanced. Please consult with us, if necessary.

Safety regulations

The coupling has to be dimensioned in that the permissible coupling load is not exceeded during any operating condition. For this purpose the actual loads have to be compared to the permissible parameters of the coupling. The customer has to protect rotating parts from accidental contact (Safety of Machinery DIN EN 292 part 2). Take precautions to make sure there is sufficient coupling protection in case of fracture of the coupling caused by overload.

Types of hubs

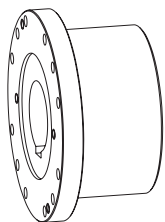

Type 1.0 hub with feather keyway and setscrew

Positive locking torque transmission, permissible torque depending on the permissible surface pressure.

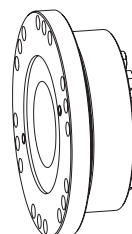

Type with KTR 620 or 603 clamping set

Frictionally engaged torque transmission with external clamping set KTR 620 or KTR 603. Transmittable torques depending on bore diameter.

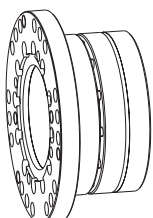

Type 6.0 and 6.5 hub

Integrated frictionally engaged shaft-hub-connection. Transmittable torques depending on bore diameter. Suitable for high speeds.

RIGIFLEX®-N

Steel laminae couplings

Technical data

The following laminae types are to be distinguished with RIGIFLEX®-N:

Size 35 – 65
(laminae with 4 holes)

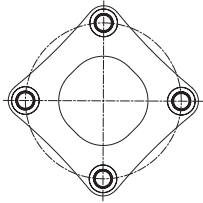

Size 75 – 160
(laminae with 6 holes)

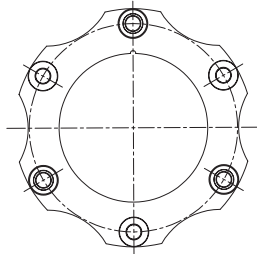

Size 166 – 406
(laminae with 6 holes)

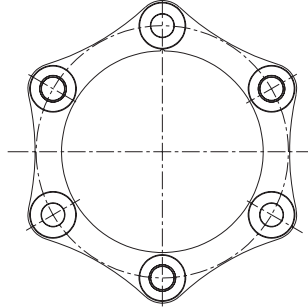

Size 168 – 408
(laminae with 8 holes)

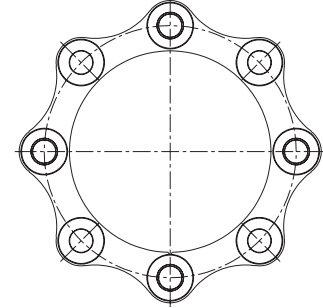

RADEX®-N

Laminae couplings

RIGIFLEX®-N

RIGIFLEX®-HP

Torques and displacements

Size	Laminae type	Torques [Nm]			Angular displacement ± K _w ¹⁾ [°]	Axial displacement ± K _a [mm]	Perm. displacements				
		T _{KN}	T _{K max}	T _{KW}			Radial ± K _r [mm]				
							E=100	E=140	E=180	E=200	E=250
35		130	260	65	0.7	1.2	0.90	1.40	–	–	–
50	laminae with 4 holes	270	540	135	0.7	1.4	0.77	1.26	–	–	–
65		550	1100	275	0.7	1.5	0.75	1.23	1.72	–	–
75		1100	2200	550	0.7	1.8	0.73	1.22	1.71	–	–
85		1900	3800	950	0.7	2.1	–	1.14	1.62	1.87	2.48
110		3500	7000	1750	0.7	2.4	–	1.05	1.54	1.78	2.39
120		5750	11500	2875	0.7	2.6	–	1.00	1.49	1.73	2.35
140		10500	21000	5250	0.7	3.3	–	–	–	1.55	2.16
160		16000	32000	8000	0.7	3.8	–	–	–	–	1.99
166	laminae with 6 holes	19000	38000	9500	0.7	3.7					
196		22500	45000	11250	0.7	4.2					
216		32000	64000	16000	0.7	4.5					
256		52500	105000	26250	0.7	5.2					
306		86000	172000	43000	0.7	6.0					
346		135000	270000	67500	0.7	6.7					
406		210000	420000	105000	0.7	7.5					
168		25000	50000	12500	0.5	2.6					
198		30000	60000	15000	0.5	2.8					
218		42500	85000	21500	0.5	3.0					
258	laminae with 8 holes	70000	140000	35000	0.5	3.5					
308		115000	230000	57500	0.5	4.0					
348		180000	360000	90000	0.5	4.5					
408		280000	560000	140000	0.5	5.0					

¹⁾ Angular displacement each laminae set

If axial, angular and radial shaft displacement arises in parallel please note the following table:

Size	Permissible angular displacement							
	0	0.1	0.2	0.3	0.4	0.5	0.6	0.7
35	1.20	1.00	0.85	0.74	0.60	0.40	0.20	0.00
50	1.40	1.20	1.00	0.80	0.60	0.40	0.20	0.00
65	1.50	1.29	1.07	0.86	0.64	0.43	0.22	0.00
75	1.80	1.54	1.29	1.03	0.77	0.52	0.26	0.00
85	2.10	1.80	1.50	1.20	0.90	0.60	0.30	0.00
110	2.40	2.06	1.71	1.37	1.03	0.69	0.34	0.00
120	2.60	2.23	1.86	1.48	1.11	0.74	0.37	0.00
140	3.30	2.83	2.36	1.88	1.41	0.94	0.47	0.00
160	3.80	3.26	2.71	2.17	1.63	1.09	0.54	0.00
166	3.70	3.17	2.64	2.12	1.59	1.06	0.53	0.00
196	4.20	3.60	3.00	2.40	1.80	1.20	0.60	0.00
216	4.50	3.86	3.21	2.57	1.93	1.29	0.64	0.00
256	5.20	4.46	3.71	2.97	2.23	1.49	0.74	0.00
306	6.00	5.14	4.29	3.43	2.57	1.72	0.86	0.00
346	6.75	5.79	4.82	3.86	2.89	1.93	0.96	0.00
406	7.50	6.43	5.36	4.28	3.21	2.14	1.07	0.00
168	2.60	2.08	1.56	1.04	0.52	0.00	–	–
198	2.80	2.24	1.68	1.12	0.56	0.00	–	–
218	3.00	2.40	1.80	1.20	0.60	0.00	–	–
258	3.50	2.80	2.10	1.40	0.70	0.00	–	–
308	4.00	3.20	2.40	1.60	0.80	0.00	–	–
348	4.50	3.60	2.70	1.80	0.90	0.00	–	–
408	5.00	4.00	3.00	2.00	1.00	0.00	–	–

RIGIFLEX®-N

Steel laminae couplings

Technical data

Permissible speeds and stiffness figures									
Size	Max. speed [rpm]	per laminae set		ct [Nm/rad] for complete coupling with mounting length E					
		cw [Nm/rad]	ct x 10 ⁶ [Nm/rad]	E=100	E=140	E=180	E=200	E=250	
35	23000	170	0.056	65020	56700	-	-	-	
50	18000	490	0.27	73953	63990	-	-	-	
65	13600	260	0.5	146022	129938	117046	-	-	
75	12400	1000	0.67	306145	278381	255234	-	-	
85	11000	1500	0.9	-	406641	369429	353265	318433	
110	9000	1500	1.5	-	664284	637587	625028	595693	
120	8000	3000	2.0	-	1798018	1637553	1567602	1416348	
140	6400	10000	3.5	-	-	-	2363340	2226630	
160	5600	10350	6.9	-	-	-	-	2654894	
166	5600	26800	13.0	Mounting dimension E as specified by the customer					
196	5200	35800	17.0						
216	4600	41500	19.0						
256	3900	65000	31.0						
306	3300	112000	55.0						
346	2900	205000	79.0						
406	2500	276000	125.0						
168	5600	44300	20.0						
198	5200	82200	26.0						
218	4600	90000	30.0						
258	3900	138000	49.0						
308	3300	234000	83.0						
348	2900	416000	125.0						
408	2500	562000	200.0						

cw = angular stiffness
ct = torsion spring stiffness

Weights and mass moments of inertia													
Size	Hub (max. bore)		Spacer complete [kg]					Spacer complete [kgm ²]					
	[kg]	[kgm ²]	E=100	E=140	E=180	E=200	E=250	E=100	E=140	E=180	E=200	E=250	
35	0.60	0.0007	1.030	1.120	-	-	-	0.00040	0.00050	-	-	-	
50	0.92	0.001019	2.262	2.442	-	-	-	0.00256	0.00263	-	-	-	
65	2.7	0.00541	3.922	4.183	4.445	-	-	0.00810	0.00830	0.00828	-	-	
75	2.4	0.00566	4.482	4.842	5.202	-	-	0.01143	0.01191	0.01239	-	-	
85	3.7	0.01135	-	7.154	7.548	7.746	8.239	-	0.02364	0.02427	0.02459	0.02538	
110	6.7	0.03222	-	12.492	13.478	13.972	15.205	-	0.06291	0.06540	0.06665	0.06976	
120	9.2	0.05238	-	-	17.324	17.842	19.137	-	-	0.10314	0.10458	0.10818	
140	18.2	0.15175	-	-	-	32.530	34.325	-	-	-	0.31901	0.32845	
160	29.9	0.33890	-	-	-	-	52.458	-	-	-	-	0.68640	
166	28.0	0.32	Mounting dimension E as specified by the customer										
196	37.0	0.554											
216	50.0	0.85											
256	95.0	2.35											
306	138.0	4.55											
346	215.0	9.75											
406	310.0	18.95											
168	30.0	0.33											
198	40.0	0.56											
218	52.0	0.88											
258	99.0	2.43											
308	142.0	4.78											
348	222.0	9.83											
408	325.0	19.22											

RIGIFLEX®-N

Steel laminae couplings

Standard type A

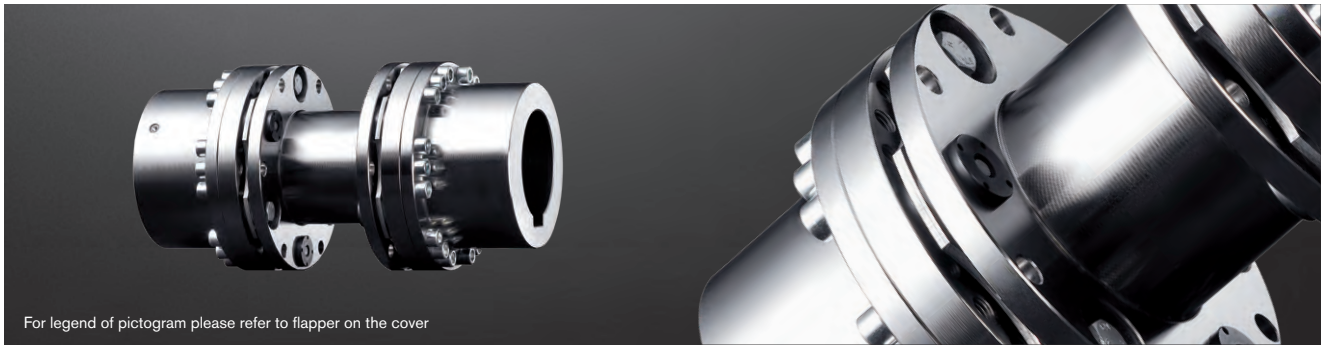

For legend of pictogram please refer to flapper on the cover

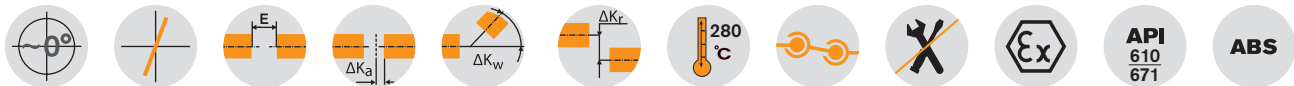

Components

Size 35

Size 50 - 408

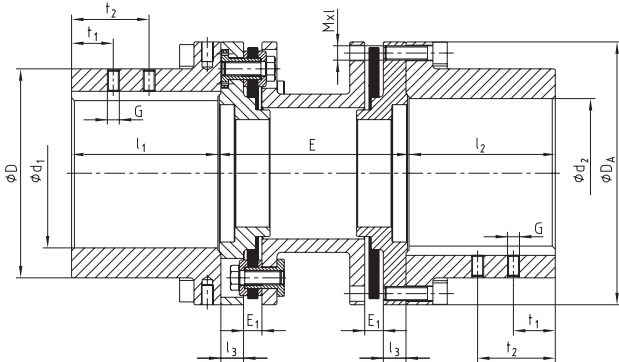
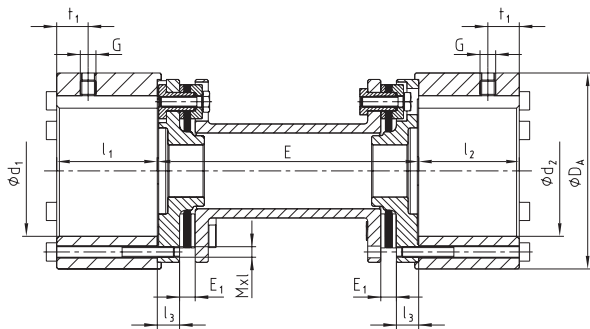

RIGIFLEX®-N type A																			
Size	Torques [Nm]			Max. finish bore	Dimensions [mm]												Screws DIN EN ISO 4762		
	T _{KN}	T _{K max}	T _{KW}		d ₁ , d ₂	D	D _A	l ₁ , l ₂	l ₃	G	t ₁	t ₂	E ₁	E ¹⁾				MxI	T _A [Nm]
35	130	260	65	50	-	75	38.5	8.5	M6	15	-	6	100	140	-	-	-	M4x45	4.1
50	270	540	135	50	70	95	50	12	M6	10	-	9	100	140	-	-	-	M6x22	14
65	550	1100	275	70	100	126	63	12	M8	20	-	11	100	140	180	-	-	M6x25	14
75	1100	2200	550	75	105	138	62.5	12	M8	20	-	11	100	140	180	-	-	M8x30	35
85	1900	3800	950	90	120	156	72.5	15	M10	20	-	12	-	140	180	200	250	M8x30	35
110	3500	7000	1750	110	152	191	87	18	M10	25	-	12	-	140	180	200	250	M10x35	69
120	5750	11500	2875	120	165	213	102	20	M12	25	-	12	-	-	180	200	250	M12x40	120
140	10500	21000	5250	150	200	265	126	25	M12	30	-	15	-	-	-	200	250	M16x50	295
160	16000	32000	8000	165	230	305	145	31	M12	30	-	15	-	-	-	-	250	M16x55	295
166	19000	38000	9500	165	230	305	155	31	M16	30	70	17					M20x50	560	
196	22500	45000	11250	195	260	330	185	32	M16	40	90	24					M20x50	560	
216	32000	64000	16000	210	285	370	205	32	M20	50	110	26					M20x65	560	
256	52500	105000	26250	260	350	440	245	38	M20	70	130	31					M24x80	970	
306	86000	172000	43000	305	400	515	295	43	M24	70	130	36					M27x100	1450	
346	135000	270000	67500	350	460	590	335	55	M24	95	175	45					M30x110	1950	
406	210000	420000	105000	405	530	675	395	58.5	M24	95	175	50	According to customer specification				M36x130	3300	
168	25000	50000	12500	165	230	305	155	31	M16	30	70	17					M20x50	560	
198	30000	60000	15000	195	260	330	185	32	M16	40	90	24					M20x50	560	
218	42500	85000	21500	210	285	370	205	32	M20	50	110	26					M20x65	560	
258	70000	140000	35000	260	350	440	245	38	M20	70	130	31					M24x80	970	
308	115000	230000	57500	305	400	515	295	43	M24	70	130	36					M27x100	1450	
348	180000	360000	90000	350	460	590	335	55	M24	95	175	45					M30x110	1950	
408	280000	560000	140000	405	530	675	395	58.5	M24	95	175	50					M36x130	3300	

¹⁾ Other shaft distance dimensions available on request.
For selection of coupling see page 18 et seqq. Assembly instruction KTR standard 47410 available at www.ktr.com.

Ordering example:	RIGIFLEX®-N 120	A	Ø 100	Ø 120	200
	Coupling size	Type	Bore d ₁	Bore d ₂	Shaft distance dimension E

RIGIFLEX®-N

Steel laminae couplings

Standard type A-J

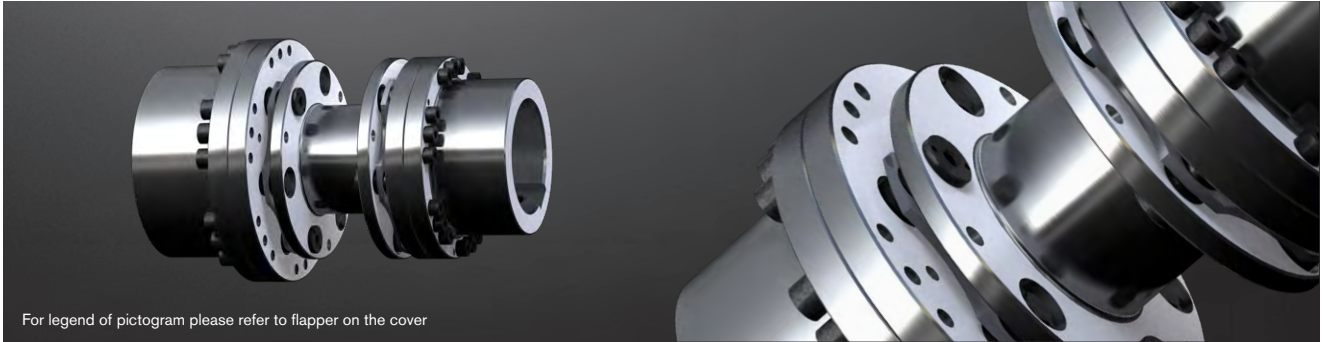

For legend of pictogram please refer to flapper on the cover



Components

Size 50 - 140

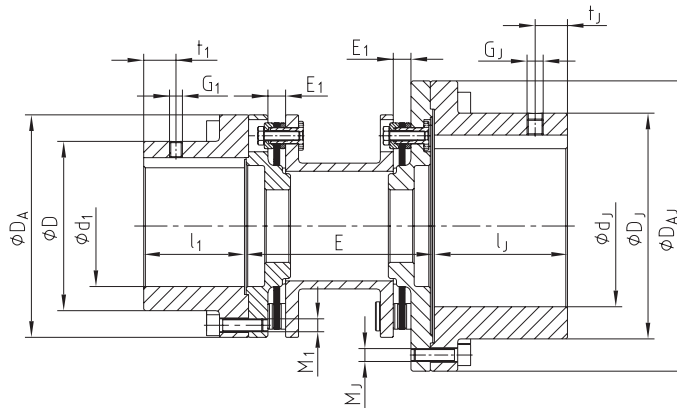

RIGIFLEX®-N type A-J																										
Size	Torques [Nm]			Max. finish bore		Dimensions [mm]														Screws DIN EN ISO 4762						
	T _{KN}	T _{K max}	T _{KW}	d ₁	d _j	D	D _A	l ₁	D _J	D _{AJ}	l _J	G ₁	t ₁	G _J	t _J	E ₁	E ¹⁾				M ₁	T _A [Nm]	M _J	T _{AJ} [Nm]		
50	270	540	135	50	70	70	95	50	100	126	63	M6	10	M8	20	9	100	140	180	-	-	-	M6	14	M6	14
65	550	1100	275	70	90	100	126	63	120	156	72.5	M8	20	M10	20	11	100	140	180	-	-	-	M6	14	M8	35
75	1100	2200	550	75	100	105	138	62.5	140	180	83	M8	20	M10	20	11	100	140	180	-	-	-	M8	35	M8	35
85	1900	3800	950	90	110	120	156	72.5	152	191	87.5	M10	20	M10	25	12	-	140	180	200	250	M8	35	M10	69	
110	3500	7000	1750	110	150	152	191	87	200	265	127	M10	25	M12	30	12	-	140	180	200	250	M10	69	M16	295	
120	5750	11500	2875	120	165	165	213	102	230	305	147	M12	25	M12	30	12	-	180	200	250	M12	120	M16	295		
140	10500	21000	5250	150	195	200	265	126	260	330	186	M12	30	M16	40/90	15	-	-	-	200	250	M16	295	M20	560	
160	16000	32000	8000	165	210	230	305	145	285	370	205	M12	30	M20	50/60	15	-	-	-	200	250	M16	295	M20	560	

¹⁾ Other shaft distance dimensions available on request.

For selection of coupling see page 18 et seqq. Assembly instruction KTR standard 47410 available at www.ktr.com.

Other types:

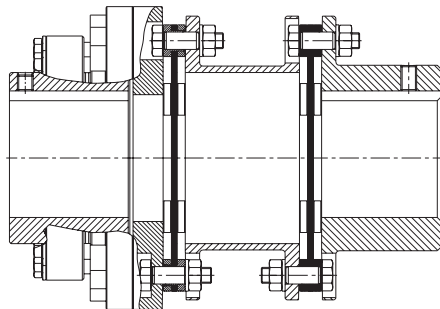

For RADEX®-N with integrated slipping unit see dimension sheet 699206

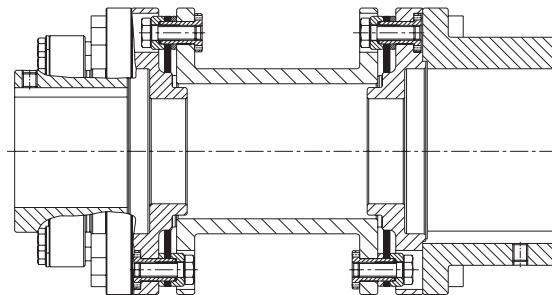

For RIGIFLEX®-N with integrated slipping unit see dimension sheet 698869

Ordering example:	RIGIFLEX®-N 85	A-J	Ø 80	Ø 120	200
	Coupling size	Type	Bore d ₁	Bore d _j	Shaft distance dimension E

RIGIFLEX®-N

Steel laminae couplings

Standard type A-H

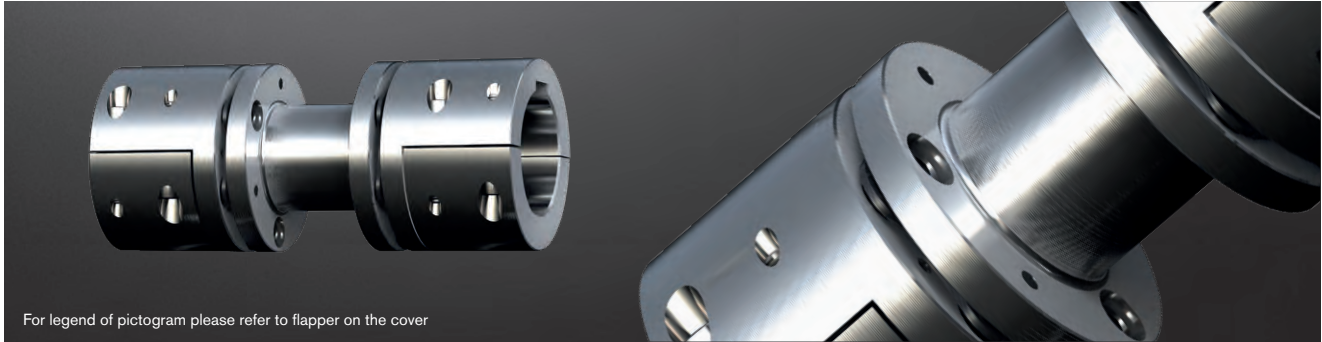

For legend of pictogram please refer to flapper on the cover

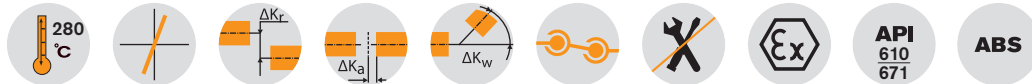

Components

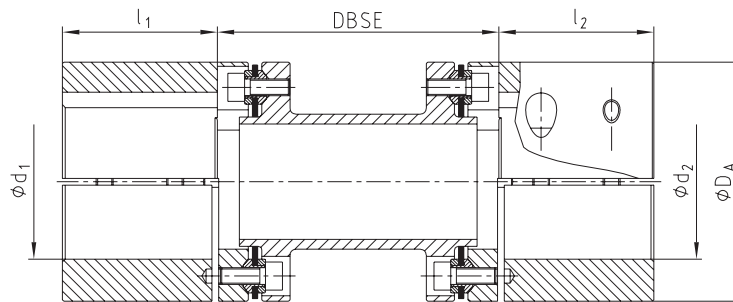

RIGIFLEX®-N type A-H											
Size	Torques [Nm]		Max. finish bore [mm]		Dimensions [mm]						
	T _{KN}	T _{K max}	d ₁ , d ₂	D _A	l ₁ , l ₂	Standard shaft distance dimension DBSE ¹⁾			Perm. axial displacement	Perm. angular displacement (per laminae set [°])	
46	90	180	42	69	45					+/- 1.4	1.0
56	255	510	55	85	55	100				+/- 1.2	0.7
66	450	900	65	105	65		140	180	250	+/- 1.6	0.7
76	975	1950	75	124	75					+/- 1.8	0.7
86	1500	3000	85	145	85	-				+/- 2.2	0.7
106	2400	4800	105	168	105		-			+/- 2.4	0.7

¹⁾ Other shaft distance dimensions (DBSE) available on request

Benefits of type A-H:

- Hub type 7.6 - half shell hub
- Easy and quick radial assembly and disassembly
- Type according to API 610 and 671 (please observe exceptions)
- Drop-out protection of spacer with fracture of laminae following API 671



Ordering example:	RIGIFLEX®-N 66	A-H	Ø 42	Ø 48	140
	Coupling size	Type	Bore d ₁	Bore d ₂	Shaft distance dimension DBSE

RIGIFLEX®-HP C

High-performance steel laminae couplings

Flange connection

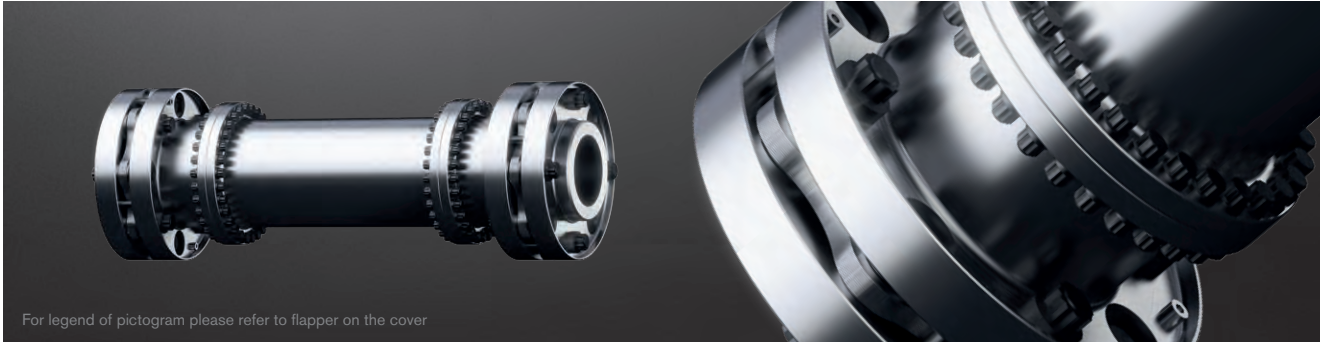

For legend of pictogram please refer to flapper on the cover



Components

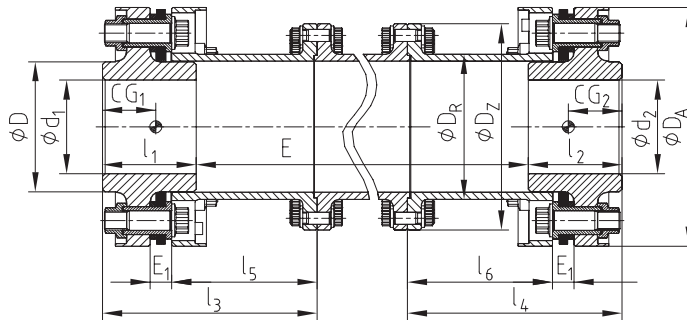

RIGIFLEX®-HP type C														
Size	Torques [Nm]		Max. finish bore	Dimensions [mm]										
	T _{KN}	T _{K max}		d ₁ , d ₂	D	D _A	D _Z	D _R	E ₁	E	E _{min}	CG ₁ , CG ₂ ²⁾	l ₁ , l ₂	l ₃ , l ₄
158	20000	26000	85	119	220	195	135	17	According to customer specification	335	46	85	189	130
168	30000	39000	100	139	255	220	155	23		395	55	100	229	155
188	38000	49400	105	147	265	235	165	23		375	55	105	229	155
208	50000	65000	120	168	298	245	186	23		350	57	120	229	155
228	59000	76700	125	178	315	270	199	33		425	65	125	265	175
248	72000	93600	140	196	335	300	217	33		395	67	140	265	175
278	115000	149500	160	225	380	335	248	33		355	70	160	265	175
318	180000	234000	180	252	445	370	280	48		495	88	180	348	225
358	253000	328900	210	295	500	415	326	48		435	93	210	348	225
388	330000	429000	235	330	545	464	362	48		400	97	235	348	225

Technical data							
Size	Max. speed [rpm]	Perm. displacements			Stiffness figures		
		Angular ¹⁾ ± K _w [°]	Axial ± K _a [mm]	Radial ²⁾ ± K _r [mm]	per laminae set c _l [Nm/rad]	Spacer c _{lR} [Nm · mm/rad]	Coupling complete ²⁾ c _{lE} = 457.2 [Nm/rad]
158	17300	0.25	3.0	2.30	13.0 · 10 ⁶	839 · 10 ⁶	1.04 · 10 ⁶
168	14900	0.25	3.0	2.32	18.0 · 10 ⁶	1535 · 10 ⁶	1.79 · 10 ⁶
188	14400	0.25	3.3	2.37	28.0 · 10 ⁶	1974 · 10 ⁶	2.23 · 10 ⁶
208	12800	0.25	3.8	2.50	35.0 · 10 ⁶	2876 · 10 ⁶	3.15 · 10 ⁶
228	12100	0.25	4.0	2.44	39.5 · 10 ⁶	4123 · 10 ⁶	5.06 · 10 ⁶
248	11400	0.25	4.2	2.58	60.0 · 10 ⁶	5410 · 10 ⁶	5.51 · 10 ⁶
278	10000	0.25	4.5	2.75	80.0 · 10 ⁶	8592 · 10 ⁶	7.94 · 10 ⁶
318	8500	0.25	5.2	2.70	105.0 · 10 ⁶	14724 · 10 ⁶	13.00 · 10 ⁶
358	7600	0.25	6.0	2.96	155.0 · 10 ⁶	26258 · 10 ⁶	20.30 · 10 ⁶
388	7000	0.25	6.5	3.18	225.0 · 10 ⁶	37596 · 10 ⁶	27.70 · 10 ⁶

¹⁾ Per laminae set ²⁾ with E=457.2 mm and cylindrical maximum finish bore

Size	Coupling ²⁾		Spacer	
	m [kg]	J [kgm ²]	m _R [kg/mm]	J _R [kgm ² /mm]
158	45	0.274	20.28 · 10 ⁻³	81 · 10 ⁻⁶
168	69	0.577	27.282 · 10 ⁻³	149 · 10 ⁻⁶
188	78	0.711	30.975 · 10 ⁻³	191 · 10 ⁻⁶
208	97	1.081	35.118 · 10 ⁻³	279 · 10 ⁻⁶
228	123	1.561	44.397 · 10 ⁻³	400 · 10 ⁻⁶
248	144	2.109	48.614 · 10 ⁻³	524 · 10 ⁻⁶
278	190	3.542	58.694 · 10 ⁻³	833 · 10 ⁻⁶
318	306	7.792	79.311 · 10 ⁻³	1427 · 10 ⁻⁶
358	405	12.869	104.041 · 10 ⁻³	2545 · 10 ⁻⁶
388	525	19.257	120.151 · 10 ⁻³	3644 · 10 ⁻⁶

$c_t \text{ total} = 1 / ((1/c_lE = 457.2) + ((E - 457.2 \text{ mm}) / c_{lR}))$
 $m_{\text{total}} = m + m_R \cdot (E - 457.2 \text{ mm})$
 $J_{\text{total}} = J + J_R \cdot (E - 457.2 \text{ mm})$

RIGIFLEX®-HP L

High-performance steel laminae couplings

Type with flange hubs

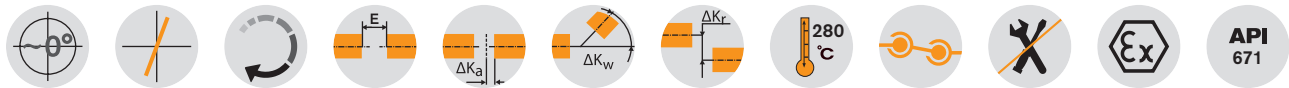
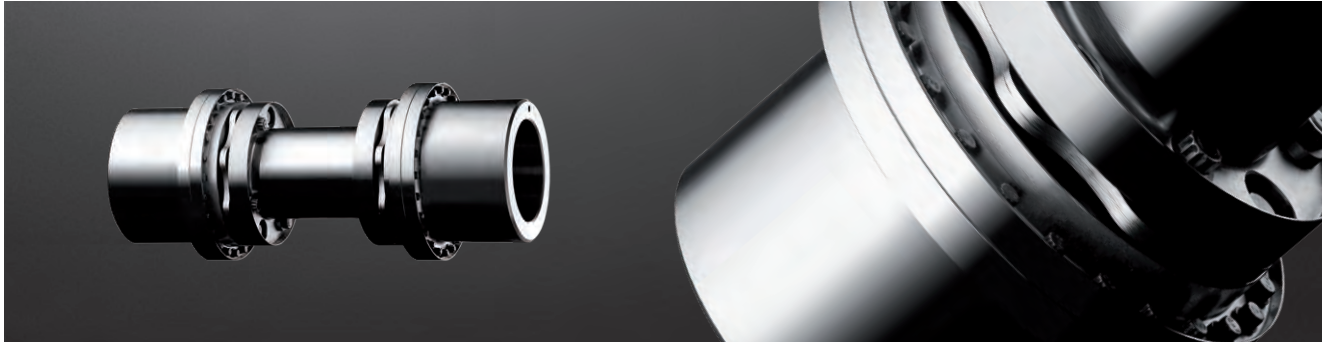

Components

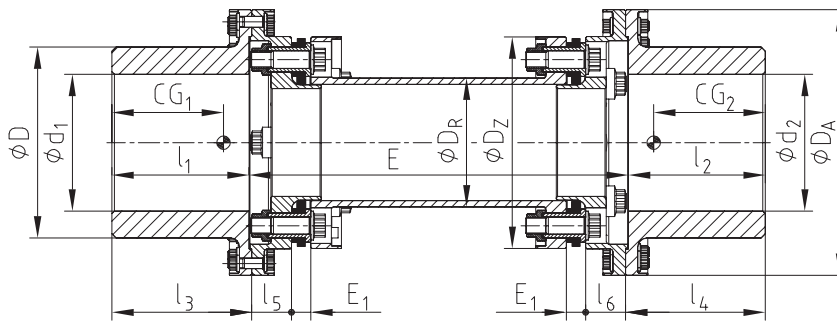

RIGIFLEX®-HP type L														
Size	Torques [Nm]		Max. finish bore	Dimensions [mm]										
	T _{KN}	T _{K max}		d ₁ , d ₂	D	D _A	D _Z	D _R	E ₁	E	E _{min}	CG ₁ , CG ₂ ²⁾	l ₁ , l ₂	l ₃ , l ₄
158	20000	26000	150	210	310	220	135	17	According to customer specification	265	140	150	163.5	37.5
168	30000	39000	165	230	320	255	155	23		340	148	165	168.5	48.0
188	38000	49400	180	250	335	265	165	23		340	156	180	183.5	48.0
208	50000	65000	200	280	362	298	186	23		340	165	200	203.5	48.0
228	59000	76700	220	310	390	315	199	33		390	179	220	223.5	54.5
248	72000	93600	240	340	420	334	217	33		390	185	235	238.5	54.5
278	115000	149500	270	380	455	380	248	33		390	202	270	273.5	54.5
318	180000	234000	315	445	550	445	280	48		510	246	315	318.5	71.5
358	253000	328900	350	490	600	500	326	48		510	263	350	353.5	71.5
388	330000	429000	380	535	650	545	362	48		510	277	380	383.5	71.5

Technical data								
Size	Max. speed [rpm]	Perm. displacements			Stiffness figures			
		Angular ¹⁾ ± K _w [°]	Axial ± K _a [mm]	Radial ²⁾ ± K _r [mm]	per laminae set		Coupling complete ²⁾	
					c _t [Nm/rad]	c _{tR} [Nm · mm/rad]		c _{tE} = 457.2 [Nm/rad]
158	13800	0.25	3.0	1.56	13.0 · 10 ⁶	839 · 10 ⁶		1.70 · 10 ⁶
168	12300	0.25	3.0	1.45	18.0 · 10 ⁶	1535 · 10 ⁶		3.00 · 10 ⁶
188	11400	0.25	3.3	1.45	28.0 · 10 ⁶	1974 · 10 ⁶		4.08 · 10 ⁶
208	10500	0.25	3.8	1.45	35.0 · 10 ⁶	2876 · 10 ⁶		5.61 · 10 ⁶
228	9700	0.25	4.0	1.34	39.5 · 10 ⁶	4123 · 10 ⁶		7.77 · 10 ⁶
248	9000	0.25	4.2	1.34	60.0 · 10 ⁶	5410 · 10 ⁶		10.70 · 10 ⁶
278	8300	0.25	4.5	1.34	80.0 · 10 ⁶	8592 · 10 ⁶		15.60 · 10 ⁶
318	6900	0.25	5.2	1.13	105.0 · 10 ⁶	14724 · 10 ⁶		26.90 · 10 ⁶
358	6300	0.25	6.0	1.13	155.0 · 10 ⁶	26258 · 10 ⁶		41.20 · 10 ⁶
388	5800	0.25	6.5	1.13	225.0 · 10 ⁶	37596 · 10 ⁶		61.30 · 10 ⁶

¹⁾ Per laminae set ²⁾ with E=457.2 mm and cylindrical maximum finish bore

Size	Coupling ²⁾		Spacer	
	m [kg]	J [kgm ²]	m _R [kg/mm]	J _R [kgm ² /mm]
158	80	0.717	20.28 · 10 ⁻³	81 · 10 ⁻⁶
168	115	1.327	27.282 · 10 ⁻³	149 · 10 ⁻⁶
188	135	1.759	30.975 · 10 ⁻³	191 · 10 ⁻⁶
208	175	2.771	35.118 · 10 ⁻³	279 · 10 ⁻⁶
228	235	4.525	44.397 · 10 ⁻³	400 · 10 ⁻⁶
248	285	6.417	48.614 · 10 ⁻³	524 · 10 ⁻⁶
278	375	10.381	58.694 · 10 ⁻³	833 · 10 ⁻⁶
318	642	24.810	79.311 · 10 ⁻³	1427 · 10 ⁻⁶
358	812	38.404	104.041 · 10 ⁻³	2545 · 10 ⁻⁶
388	1016	57.062	120.151 · 10 ⁻³	3644 · 10 ⁻⁶

Ordering example:	RIGIFLEX®-HP 188	L	Ø 160	Ø 180	457.2
	Coupling size	Type	Bore d ₁	Bore d ₂	Shaft distance dimension E